

REVISIONS		
REV. NO.	DESCRIPTION	DATE

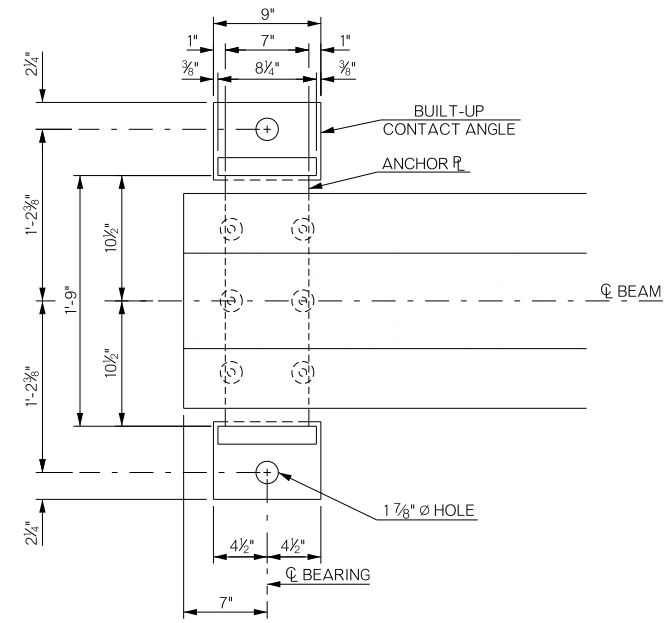

FIXED BEARING PLAN
AT ABUTMENTS 1 & 2

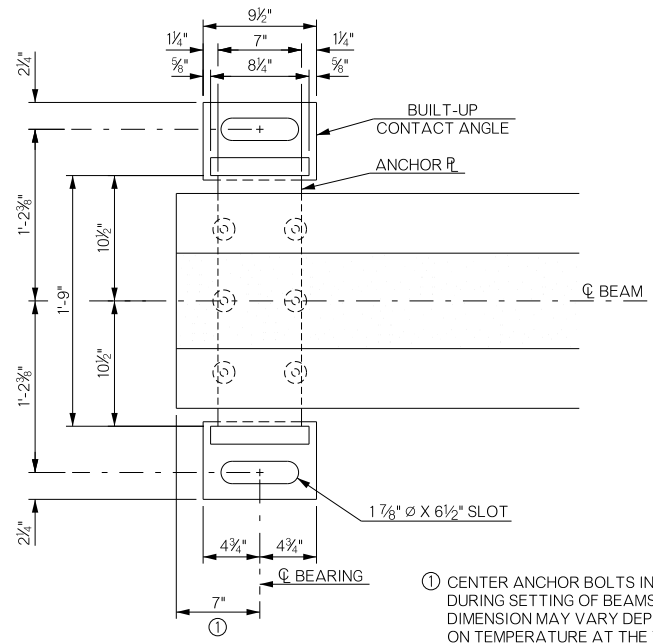

EXPANSION BEARING PLAN
AT PIERS 1 & 2

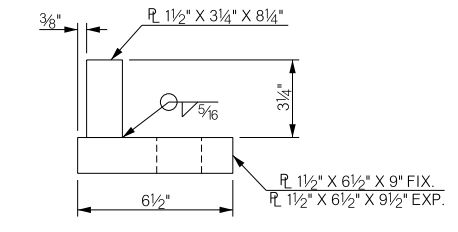

BUILT-UP CONTACT ANGLE DETAIL

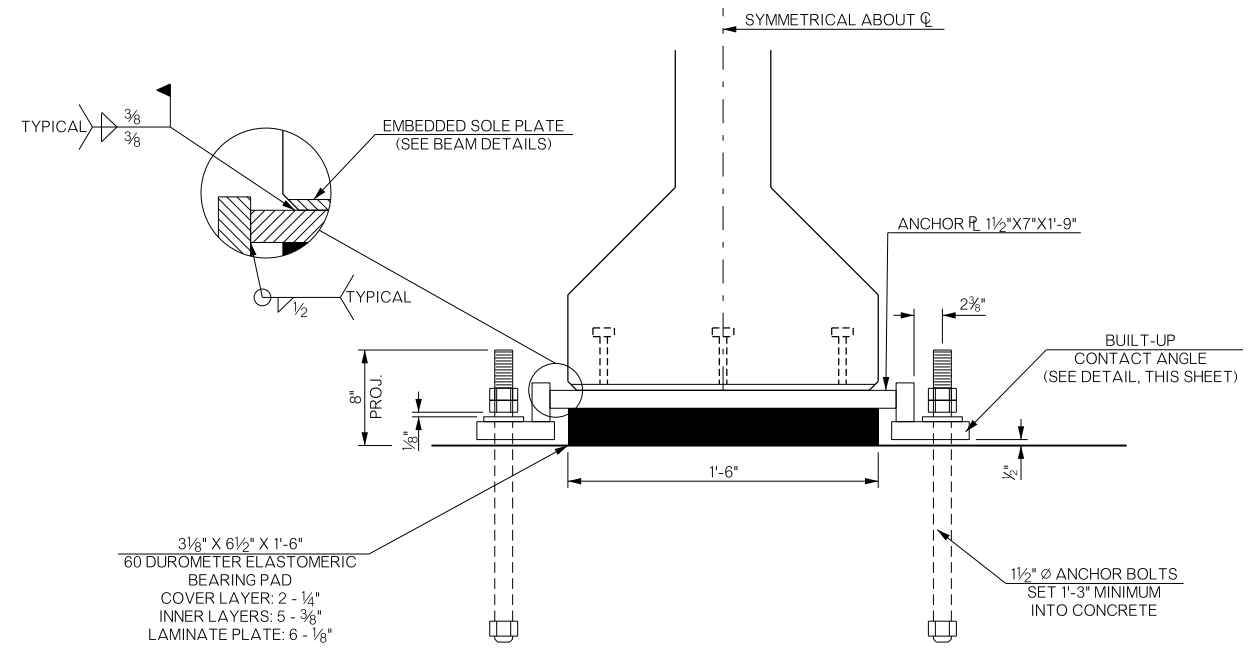

END VIEW

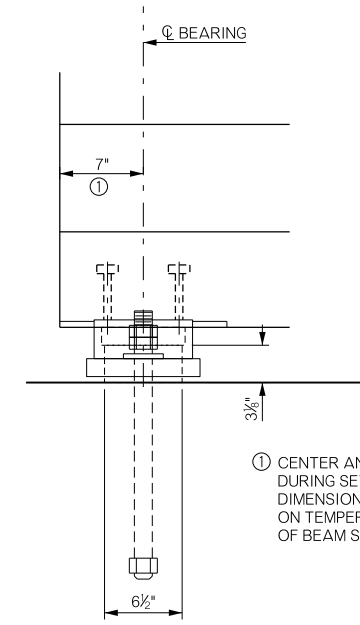

SIDE VIEW

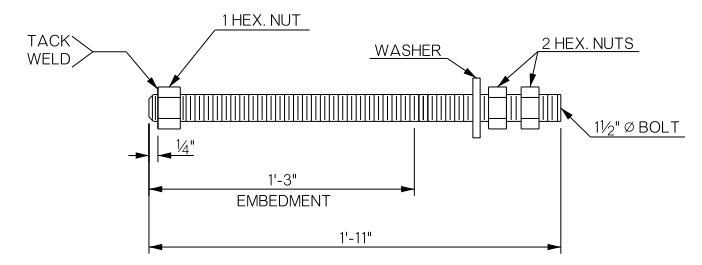

ANCHOR BOLT DETAIL

3 1/8" X 6 1/2" X 1-6"
60 DUROMETER ELASTOMERIC
BEARING PAD
COVER LAYER: 2 - 1/4"
INNER LAYERS: 5 - 3/8"
LAMINATE PLATE: 6 - 1/8"

BRIDGE "B" U.S.-277 over SNAKE CREEK	COMANCHE COUNTY	Design	MLC	07/16
DETAILS OF BEARING ASSEMBLY		Detail	VNT	07/16
		Check	DAH	04/17
STATE OF OKLAHOMA		Squad	HARJO	
DEPARTMENT OF TRANSPORTATION		Engr:	MOLLA-ESMAIL	
JOB/PIECE NO. 27968(04)	SHEET NO. B026			